

**SCOPE:** This specification applies to Magnetic Transducer TRTE-2512PS

**1. SPECIFICATIONS**

PARAMETERS	VALUES	UNITS
*MIN SOUND PRESSURE LEVEL AT 10 CM	85	dB
RATED VOLTAGE	12	Vo-p
OPERATING VOLTAGE	8 - 14	Vo-p
REPRODUCED FREQUENCY	1,000 - 1,500	Hz
*MAX OPERATING CURRENT	55	mA
COIL RESISTANCE	120 ± 15	Ohm
OPERATING TEMPERATURE	-20 to +70	°C
STORAGE TEMPERATURE	-30 to +85	°C
HOUSING	NORYL	-
WEIGHT	10	g

\*Value applying rated voltage (1/2 duty square wave, 1,000Hz)

**2. DIMENSIONS (unit in mm)**

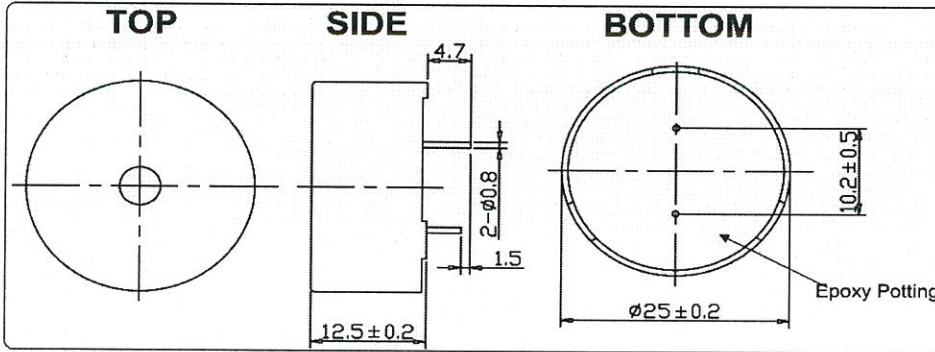

Tolerance: ±0.5mm except specified

**3. RECOMMENDED CIRCUIT**

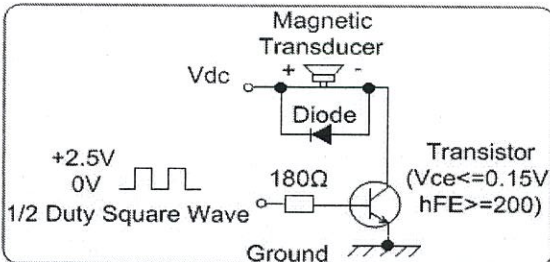

Transducers USA  
Confidential and Proprietary

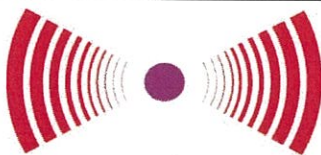

**Transducers USA**  
1400 Howard Street  
Elk Grove, IL 60007  
Toll Free: 888-921-6400 FAX: 847-956-1950  
[www.tusainc.com](http://www.tusainc.com) info@tusainc.com

All dimensions are in MM unless otherwise specified

Drawing Number:  
**TRTE-2512PS**

**Magnetic Transducer**

Date:  
12/07/2007

THE INFORMATION DISCLOSED HEREIN WAS ORIGINATED BY AND IS THE PROPERTY OF TRANSDUCERS USA, INC. AND EXCEPT FOR USE EXPRESSLY GRANTED TO THE UNITED STATES GOVERNMENT, TRANSDUCERS USA, INC. RESERVES ALL PATENT PROPRIETARY DESIGN, USE, SALE, MANUFACTURING AND PRODUCTION RIGHTS THERETO. THIS DOES NOT APPLY TO VENDOR