

# SPECIFICATION

## 1. SCOPE

This specification is applied to the piezo-element.

## 2. SPECIFICATION (at 25° °)

- 2.1 Resonant Frequency : 2.6 ± 0.5 KHz
- 2.2 Resonant Resistance : 300 Ω max
- 2.3 Capacitance : 30000 pF ± 30% at 100Hz
- 2.4 Input Voltage : 30 Vp-p max
- 2.5 Operating Temperature : -20° +50 ° °
- 2.6 Storage Temperature : -20° +60 ° °

## 3. DIMENSION as per figure

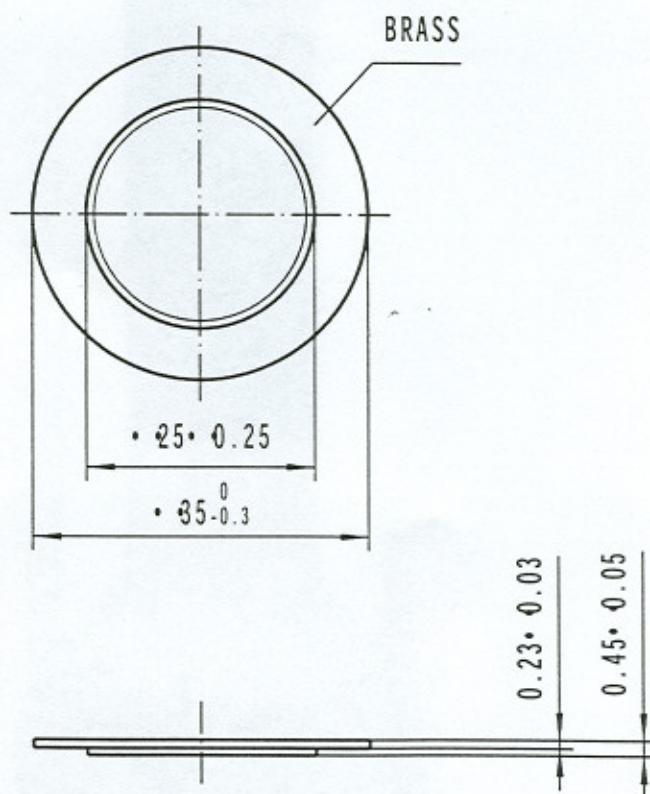

### Transducers USA

1400 Howard Street  
 Elk Grove Village, IL 60007  
 Toll Free: 800 956-1920 Fax: 847 956-1950  
 www.tusainc.com info@tusainc.com



Drawing Number:

TRPB-3526

Title:

PIEZO BENDER

All dimensions are in MM unless otherwise specified

Date: 10/29/04

THE INFORMATION DISCLOSED HEREIN WAS ORIGINATED BY AND IS THE PROPERTY OF TRANSDUCERS USA, INC. AND EXCEPT FOR USES EXPRESSLY GRANTED TO THE UNITED STATES GOVERNMENT, TRANSDUCERS USA, INC. RESERVES ALL PATENT PROPRIETARY DESIGN, USE, SALE, MANUFACTURING AND REPRODUCTION RIGHTS THERETO. THIS DOES NOT APPLY TO VENDOR PARTS